



## SEED CLEANER

### MODEL - UC-1



The UC-1 is the first in a line of small cleaners designed to meet the low maintenance and easy clean out requirements of today's seedsman. The UC-1 is built with the same care and Craftsmanship as AGROSAW's large precision cleaner.

The UC-1 feature a heavy duty tubular steel frame 50x50mm, FFP plywood (Thik.21 mm) and a heavy duty eccentric cradle drive.

#### Screens

The UC-1 cradle has been designed with three 556 X 610 mm screens. One screen for the top and the other two for lower separation.

#### UC-1 Commodity Flow

The commodity is fed into the hopper and is spread evenly across the full width of the top screen. The product than moves across the top screen, which has opening larger than the product itself.

The large foreign material is "scalped" off while the good product falls through the screen.

The bottom two screens are set up for split flow sifting. The bottom screen opening must be smaller than the commodity being cleaned. Trash , weed seed and splits drop through the bottom screens while good product passes over them. The bottom two screen can also be set up as a scalp/sift flow by removing the two- way splitter.

Next, the product is routed through a column of air from the bottom blast fan. This blast of Air effective removes any lightweight trash and dust that may have remained after screening. Good clean product is discharged at the bottom of the air chamber

#### Machine screen arrangement facility:-

1. Double scalping single grading. than the product itself.
2. Single scalping double grading.
3. Single scalping single grading with relief screen.

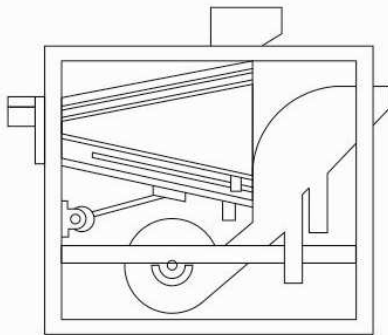

#### TECHNICAL SPECIFICATIONS

Model	Cap. Fine Cleaning	Cap. Fast Cleaning	LxWxH	Feeding Height (Manual Feeding)	Feeding Hopper Flap Opening	No. of Screens	Seed Output	Size of Each Screen	Cleaning Device	No. of Blower	Power Consumption
UC-1	1 tph	2 tph	1380x1008x1580 mm	1580 m	Back and Pinnion	Three	Over Size, Under Size Final and Air Remove	556x610 mm	All Three Screens has Ball Cradle	One	One H.P. Single Phase 1440 RPM 220V

Note: Capacities may vary depending on seed condition, moisture content, seed varieties, type and volumes of contaminants to be separated and the percentage of foreign material acceptable in the final product. Capacity also vary depending on product flow through the cleaner.

\*Capacity based on wheat



**AGROSAW**  
DETERMINED TO PRODUCE BETTER

ISO 9001 : 2008  
ISO 14001 : 2004  
OHSAS  
18001 : 2007  
IS 18001 : 2007  
SA 8000 : 2001



**Our Other Products :** • Seed/Grain Cleaning, Grading & Handling Equipment • Seed/Grain Dryers • Seed Treators & Coaters  
Seed/Grain Storage Silos • Fruit & Vegetable Cleaning, Grading, Sorting & Handling Equipment

We also plan, design, manufacture & commission seed processing, grains/spices/pulses cleaning and handling plants on turn-key basis. Due to constant process of research & development, all designs and specifications are subject to change without prior notice. Capacities mentioned are based on wheat.

Osaw Agro Industries Pvt. Ltd.

P.O. Bag 5, Agrosaw Complex, Jagadhri Road, Ambala Cantt.-133 001 India Phones : (0091) 171 2699354, 2699167, 2699547 Fax : (0091) 171 2699018  
E-mails : agrosaw@agrosaw.com, agrosaw@rediffmail.com Web : www.agrosaw.com